

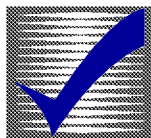

HOW-TO BOOKLET #3064

BRICK WALKS



TOOL & MATERIAL CHECKLIST

- Bricks
- Sand and/or Mortar Mix
- Forming Materials
- Hammer
- Nails
- Saw
- Level
- Shovel
- Spade
- Broom
- Garden Hose

Read This Entire How-To Booklet for Specific Tools and Materials Not Noted in The Basics Listed Above.

Brick walkways, properly maintained, add an aesthetic feeling to landscaping like no other building material. The earth tones of the brick blend in with any style architecture, and as a bonus, the bricks offer a hard surface for walking, work, and play.

Laying a brick sidewalk—formal or informal in style and design—is easy for do-it-yourselfer mainly because the project can be completed in stages—unlike concrete, which must be worked immediately.

DESIGN CONSIDERATIONS

Be versatile when you plan a brick walkway project. If the walkway will meet a patio or terrace or fence, leave an open area between the two. Later, the area can be formed into a raised planting bed or just left as a pleasing grassy area. Also, rather than removing trees or shrubs, build the walkway around them. Each tree or plant will require an open area equal to at least 1-1/2 to 2 feet in diameter. This permits an adequate amount of moisture to reach the roots and enough space to grow.

It is recommended that you make a sketch of your project on graph paper, tracing in trees, shrubs, plantings, fences, walls, patios, and so on. Then determine where the walkway best fits in the plan.

Materials and Edging. The walkway can be constructed of bricks laid in mortar bed on a concrete footing or in a sand bed over a gravel base. Often, brick installations such as these feature permanent edging materials, such as bricks set on end, special wood beams, or even old railroad ties. The edging holds the shape of the walk and increases its longevity. Bricks tend to “float” if they are not contained within a form of some sort.

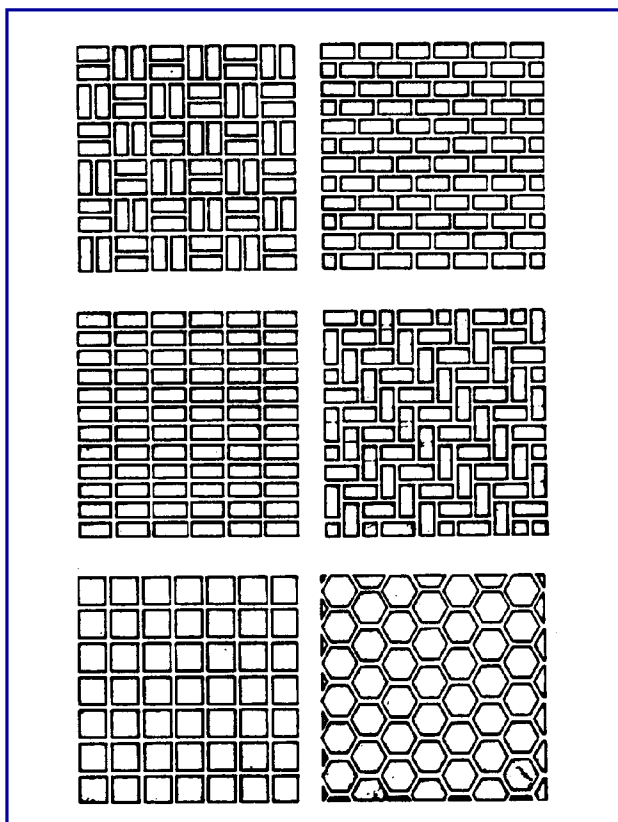

Creating Edging Patterns. The type of permanent edging you choose will affect the design of the project. A walkway that is straight-away, can have an edging of 2X4s or 4X4s of redwood, cypress, or pressure treated lumber. Old railroad ties also make super edging for walks. Sink them into the ground to about half the thickness of their top edges so the wood surface will stand only a little higher than the tops of the bricks. You can create additional designs using the wooden edging materials in interior patterns that divide the walkway into “sections.”

If the walkway will go around a tree, for example, you may want to create a circle around the tree with bricks. Or, you may want to turn the walkway with a gentle curve, or even widen certain sections on which garden furniture and plantings may be set. You can work with curved, round, and free-formed shapes with an edging of bricks set in a small concrete footing.

ALL ABOUT BRICKS

Bricks manufactured today have changed little in design and manufacture from those that were produced thousands of years ago. The big difference is that the old bricks were sun baked or dried in the sun, but today’s bricks are heated in a kiln to harden them and to make them more resistant to moisture and the weather.

The standard size of a brick—2-1/4x3-3/4x8 inches—has not changed significantly from the days when brick makers figured out that the unit was just about the right size to handle easily with one hand.

Although there are a great number of different kinds of bricks, there are four basic types used in most modern construction.

Building or Common Brick. This is the most economical and popular brick made. It can be used for almost any type of construction—including walkways. Because the color and dimensional size of common brick varies, it is especially suitable for walkways. Building or common bricks are available in three different grades:

- 🏠 **SW:** This brick will withstand severe weathering such as freezing, thawing, or rain-and-freeze conditions. These are the most expensive grade of common brick.
- 🏠 **MW:** This grade withstands modest weathering, including some rain and freezing, but cannot be used in areas of severe weathering.
- 🏠 **NW:** NW bricks can be used in mid climates where there is no danger from freezing or frost. They are also suitable for frost areas, but only if the bricks are protected from rain or moisture.

Face Brick. Face brick is the best quality brick. It is manufactured so that all bricks are uniform in color, size, texture, and face surface. It is more expensive than common brick.

Paving Brick. Paving brick is extremely strong and sturdy. It is made to be used without mortar for walkways, driveways, courtyards. The paving brick is composed of special types of clays that are baked at higher temperatures and for a longer time than other brick types. The result is a very durable and strong brick.

Firebrick. This material is used to line fireplaces, and it is not recommended as a paving type product.

SAND-BED BRICK WALKWAYS

Laying brick in a bed of sand is by far the easiest way to create a walkway. If you follow the proper procedures, and if the climate is mild, the job will last as long as if laid in a bed of mortar.

Pay careful attention to proper grading and installation of the sand bed, or else the project will look shoddy and haphazard. Remember, too, that no matter how carefully you work on the sand bed, it will still settle somewhat, resulting in depressions in the brick surface after the job has been completed. To remedy the problem, remove the bricks that have sunk down, place more sand beneath them, and then replace the bricks, filling the joints with sand.

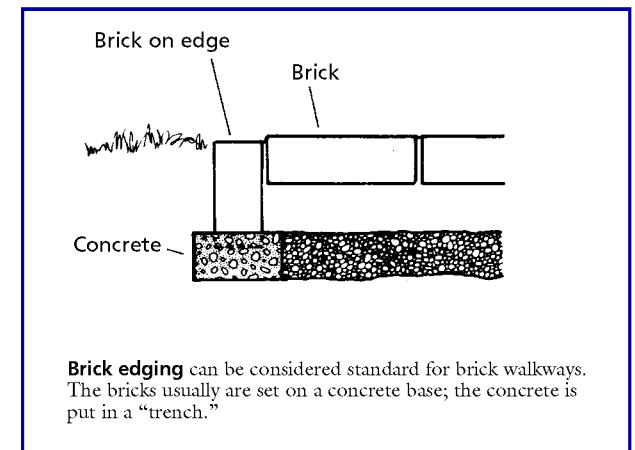
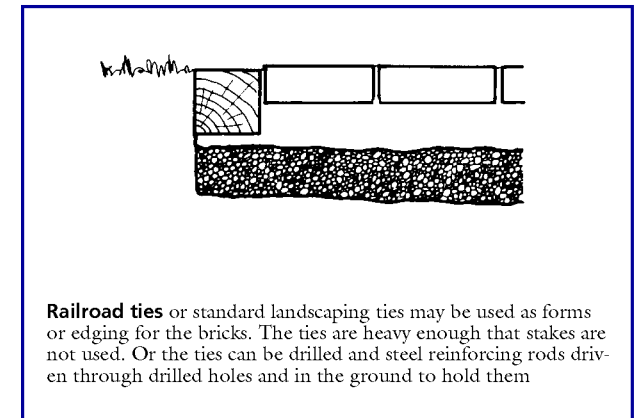
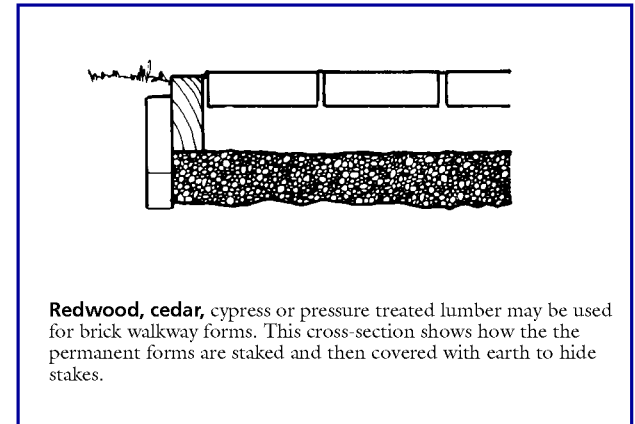

Excavating the Subgrade. One of the prime prerequisites to creating a good-looking, long-lasting brick walkway is a solid, well-packed sub-surface. Usually, you need only cut away the turf to the depth necessary to accommodate 2 inches of sand and the thickness (or part of it) of the bricks. The paving material often reaches as much as 2 inches above the ground level.

Clear away all rocks and debris from the area and smooth it out as much as possible. In areas where the soil is not naturally well-packed or does not drain properly, you may need to first add a layer of well-tamped gravel or crushed stone fill. If this layer is added, adjust the depth of the excavation to suit. Even a well-packed soil surface can be improved by tamping it thoroughly before the sand bed is set.

INSTALLING EDGING OR FORMS

Permanent wood borders should be made of cypress, redwood, or cedar. These species resist rot. However, they can be expensive depending on the area in which you reside. Or, you can use less-expensive pressure treated (PT) lumber. It will rot, but it takes years before replacement is needed.

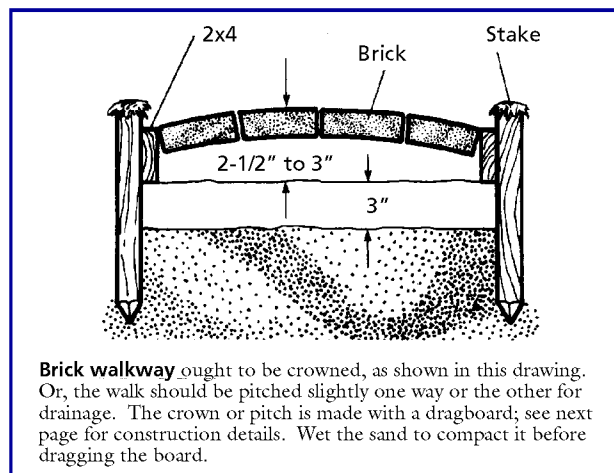

After the excavation is completed, install the edging so that the top edge is just above, or flush with, the ground level. To anchor the edging solidly in place, install stakes made of the same material as the forms. Nail the forms to the stakes with double-headed nails. Fill in the base and the sand bed; lay the bricks. Finish as desired. Remove the nails from the stakes. Using a wedge-shaped piece of 2X4, pound the permanent stakes below ground level. Do not pound on the edging. Cover the stakes with soil; they won't show.

Temporary Forms. You can build a temporary form; its purpose is to hold the bricks in position until the project has been completed.

When the bricks are in place, remove the form. Then pack earth around the outside edges of the bricks. This installation, of course, is not as stable or long-lasting as one that has a permanent edging.

Pitching the Walk. If possible, the walkway should be slightly pitched or crowned so water runs off its surface. You don't need much pitch or crown; it probably won't even be noticeable to the eye. A pitch or crown is made by shaping the sand bed accordingly. High on one side, low on the other. Or, make the sand higher in the center.

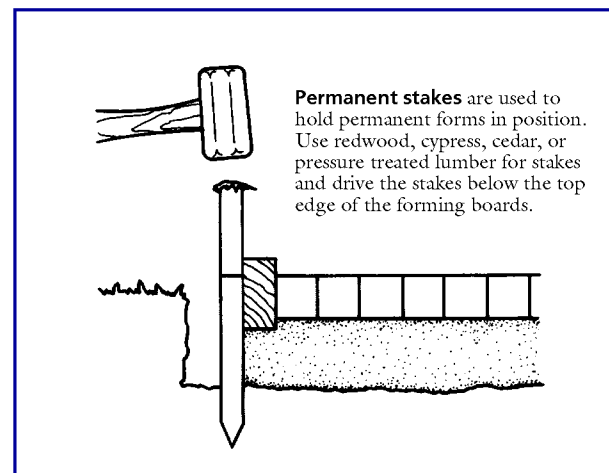

Deter Vegetation. After the earth has been tamped, you can install a sheet of black polyfilm (4 mils thick, if you can buy it) on top of the earth and below the sand fill. This plastic will help prevent grass, weeds, and other vegetation from growing up between the sand joints of the brick walkway. However, it will not stop wind-carried seeds that anchor themselves in the sand joints. You can use vegetation killing chemicals to remove this growth for at least one year.

ADDING THE SAND BASE

After the edging has been installed, place and tamp any gravel fill. Then add a layer of sand that is at least 2 inches deep. Spread the sand roughly in place with a rake. With a hose set on fine spray, thoroughly dampen the sand. In a short time, the sand will settle and become somewhat hard.

Fill in the spots that are obviously low, and dampen the new fill. While the sand is still wet, pull a dragboard across the edging to level the sand bed. Remove any excess and fill in low spots as you drag the leveling board across the sand surface.

Sprinkle the sand bed again after leveling it. Use a fine mist only; you don't want to dislodge the sand.

Crowning the Walk. The paved surface must be built so water can run off it. Although some moisture will soak down through the cracks between the bricks, you still need a way for most of the surface water to drain away quickly.

To provide the necessary pitch to the walk, the center is crowned—somewhat raised in the center. Crowning also adds another benefit: Since traffic along a walk eventually will drive and pack down the center, crowning prevents the center of the walk from becoming lower than the edges of the walk.

Crown the sand by creating a dragboard that is higher in the center than at the ends. Cut the dragboard to produce a little pitch, too.

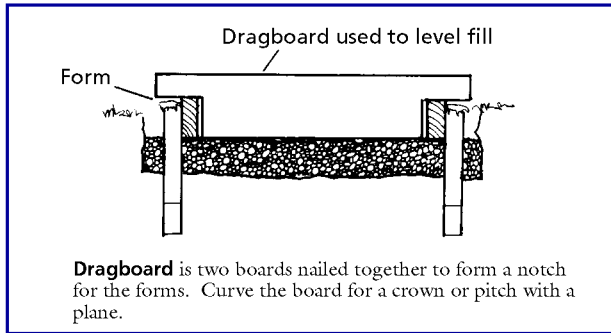

SETTING THE BRICK

Start at one end or corner of the project. Position the brick in the pattern you want. To embed the bricks into the sand, lay a 16-inch piece of 2X6 over the bricks and hammer them down. Run a long level or straightedge across the surface to make sure that the finished surface is level to the edging and that the bricks are level with each other.

Set the paving bricks 1/4 to 1/2 inch higher than the desired final height of the finished surface, since the bricks will settle after a time. Butt the bricks, or allow for consistently sized joints between the pavers. You may have to tap them together in some areas. When tapping, protect the surface of the brick with a buffer board; the hammer can chip, crack, or break the brick units.

LAYING BRICK PATTERNS

There are several patterns used in brick walkways, including some that aren't used in walls and other vertical structures. Two possible choices are herringbone and basketweave. The careful layout required for any horizontal brick surface is obvious in the following example, which is a discussion of a basketweave pattern.

LAYING THE BASKETWEAVE DESIGN. A basketweave pattern is based upon blocks of brick set on edge at right angles to each other. Each block must be of equal size. Arrange joint sizes so that the two or three bricks set in one direction equal the length of the brick.

Three-Brick Basketweave. Beginning in one corner, place three bricks on edge. All should run in the same direction, and there should be a 3/8-inch joint left between them. The size of the brick will equal the length of the bricks (7-5/8 inches), which should equal the sum of the three thickness and the two joints ($2-1/4 + 3/8 + 2-1/4 + 3/8 + 2-1/4$) to yield a 7-5/8 x 7-5/8-inch square.

Now set the second block of three bricks at right angles to the first block. To assure the correct spacing, align the top and bottom brick with the top and bottom edges of the lengthwise brick they butt against. To complete the block, center the third brick between the two. Continue alternating blocks, working out and across the walk area. Try not to go back to an area already completed since you could disturb the spacing of the bricks.

Two-Brick Basketweave. If you want to lay the bricks flat rather than on edge, each block will contain only two bricks. Again, work on aligning outside edges to create equal squares.

FILLING THE JOINTS

For sand fill, after laying the bricks, start at one end or corner and spread dry sand on the surface. Sweep the sand down into the cracks between the bricks. Work on one quarter at a time, sweeping from all directions to fill all the joints completely.

This job will take a lot of patience—and sand and sweeping. You've heard the old adage: "pounding sand down a rat hole." This job is similar. You will think the joints will never fill up. But they will.

When the joints appear to be full, lightly hose the surface to pack down the dry sand. then sweep any excess off the surface. You probably will have to repeat this process at least 10 times until the joints are completely full of sand. And, from time to time, you will have to sweep in more sand to keep soil and weeds from working up through the joints. This is where the polyfilm barrier can save you some time.

SAND/MORTAR FILL. You can place mortar in the joints of a sand-bed walk if you wish, but the mortar joints will crack and won't look as neat as the sand-filled joints. Mortar the joints by applying a dry mix of 1 part cement and 4 parts sand.

Place the dry mix in and around the bricks. Pack all joints with the mix, and then moisten the mix by spraying it with a garden hose. Continue the light spray for half an hour. Don't flush away any of the mortar with high water pressure. Over the next few days, dampen the surface once again. The concrete will bond with the sand to form a hard joint. Repeat the process every year, after cleaning out broken and chipped concrete.

